

User Manual

Immersion thermocouple type J with J-Head

Order nr.803313 1111



HP / CK 03.07.2024

All rights reserved. Changes to the documents are not allowed. Please read the operating instructions before starting any work and keep them carefully and to hand.

Testo Sensor GmbH

Testo-Straße 1
D-79853 Lenzkirch

+49 7653 96597-71
webshop@testo-sensor.de

Managing Director: Prof. Burkart Knospe, Martin Arndt, Timo Löffler
Amtsgericht Freiburg HRB 706025 | Umsatzsteuer-ID.: DE274417683
Please find our whole temperature probe and transmitter portfolio in our webshop at: www.testo-sensor.shop

1. Table of content

- 1. General 3
 - 1.1. Security..... 3
 - 1.2. Intended use.....3
 - 1.3. Personnel qualification..... 3
 - 1.4. Signage, safety labels, type plate..... 4
- 2. Transport, packaging and storage..... 44
- 3. Commisioning..... 4
 - 3.1. Assambly..... 4
 - 3.2. Requirements for achieving the protection class (IP 65)..... 4
 - 3.3. Drilling template 4
 - 3.4. Pin assignment..... 5
 - 3.5. Maintenance 5
 - 3.6. Disposal 5
- 4. Technical data and assembly instructions..... 6
- 5. Characteristics.....13

HP / CK 03.07.2024

Testo Sensor GmbH

Testo-Straße 1
D-79853 Lenzkirch

+49 7653 96597-71
webshop@testo-sensor.de
Please find our whole temperature probe and transmitter portfolio in our webshop at: www.testo-sensor.shop

Managing Director: Prof. Burkart Knospe, Martin Arndt, Timo Löffler
Amtsgericht Freiburg HRB 706025 | Umsatzsteuer-ID.: DE274417683

1. General

- The temperature probe described in the operating instructions is manufactured according to the current state of the art. All components are subject to strict quality and environmental criteria during manufacture. Our management systems are certified according to ISO 9001 and ISO 14001. The general terms and conditions in the sales documents apply, subject to technical changes.
- These operating instructions are an important part of the product. It must be available to qualified personnel and must be carefully read and understood before starting any work. Please be sure to comply with all the safety and handling instructions given. In particular, observe the local accident prevention regulations and general safety regulations applicable to the area of use of the product.
- The manufacturer's liability expires in the event of damage caused by improper use, non-observance of the instructions, use of insufficiently qualified personnel and unauthorised modifications to the product.

1.1. Security

WARNING! Before installation, commissioning and operation, please make absolutely sure that the correct temperature probe has been selected with regard to design and specific measuring conditions. Failure to do so may result in serious personal injury and/or damage to property.

- The selection of the products and, in particular, the determination of their suitability for a specific purpose are the sole responsibility of the purchaser, who must also ensure that incorrect planning, operation or installation does not cause any further damage and that compliance with the relevant construction and safety guidelines is observed and guaranteed.
- No liability or warranty is expressly accepted for damage caused by incorrect planning, operation, installation or malfunction of the products.
- The technical data and connection conditions in the supplied installation and operating instructions apply exclusively. Changes are possible in the interests of technical progress and the continuous improvement of our products.

1.2. Intended use

- For the intended use of the probe, please refer to the technical data and the commissioning instructions in the operating instructions. The product is designed and built exclusively for the intended use described there and may only be used accordingly. The technical specifications must be observed. Claims due to improper use are excluded.
- This product must not be used for safety-relevant tasks, such as monitoring or protecting persons against danger or injury, as an emergency stop switch on systems or machines, etc.
- This type of temperature probe has been developed, qualified and manufactured to the highest quality standards. Application-specific environmental or stress conditions can influence the behaviour and lead to deviations from the specifications in the data sheet. To avoid this, we recommend application-specific advice.

Application-specific environmental or stress conditions can be in particular:

- Ingress of humidity, which can lead to falsification of measured values
- Vibration, which causes high acceleration forces
- UV irradiation, which can lead to embrittlement of the cable insulation
- Tensile forces acting on the cable, which can damage the probe's internal structure
- Insufficient thermal coupling to the measured medium, with increased response times as a result
- Impact with excessively high temperatures, which can change or destroy the built-in measuring resistor or electronic components
- Corrosion at the cable ends or the connector contacts, so that measured value falsifications can occur

1.3. Personnel qualification

WARNING! - Risk of injury due to insufficient professional qualification! Improper handling can lead to considerable personal injury and damage to property.

- The activities described in these operating instructions may only be carried out by adequately qualified personnel. Special operating conditions may require additional, appropriate knowledge, e.g. about aggressive media, possible dangers or country-specific regulations, standards or guidelines. Please keep unqualified personnel away from the danger areas.

1.4. Signage, safety labels, type plate

Products are labelled as follows. (Exemplary representation)

Label for temperature probes with housing/head



Label for cable probes (attached to the cable as a flag)



2. Transport, packaging and storage

Transport: Please inspect the product for any transport damage immediately after delivery. Please notify us immediately of any obvious damage.

Packaging: Please remove the packaging only immediately before assembly and keep it, as the packaging provides optimum protection during transport.

Storage: The permissible storage temperature is -20 ... +70 °C and the ambient humidity conditions at the storage location should preferably be approx. 20% ... 85% relative humidity; condensation should be avoided.

The following influences should be avoided:

- Direct sunlight or proximity to hot objects
- Mechanical vibration, mechanical shock (hard impact)
- Exposure to soot, steam, dust or corrosive gases
- Explosive environment, flammable atmospheres

Original packaging: Please store the product in the original packaging in a place that meets the conditions listed above. If the original packaging is not available, please pack and store the product as follows:

- Wrap the product in an antistatic plastic sheet.
- Place the product with the insulation material in the packaging.
- For longer storage (more than 30 days), add a bag of desiccant to the packaging.

3. Commissioning

3.1. Assembly

- The products may only be connected in a de-energised state, only to safety extra-low voltages and only by suitably qualified personnel.
- Please observe the safety regulations of the VDE, the federal states, their monitoring bodies, the TÜV and the local EVU. The installation instructions in the data sheet must be observed.
- Please observe EMC guidelines to prevent damage, faults on the product or measured value deviations.

3.2. Requirements for achieving the protection class (IP 65)

- Only use the cable gland in the specified clamping range (select the cable Ø to match the cable gland).
- Do not use the lower clamping area when using very soft cable types.
- Only use round cables (a slightly oval cross-section may also be suitable).
- Do not twist the cable.
- Multiple opening/closing is possible, but can have a negative effect on the protection class.
- For cables with pronounced cold flow behaviour, please tighten the screw connection if necessary.

3.3. Drilling template

You will find the drilling template, if available, in the technical data.

3.4. Pin assignment

The characteristics of our sensors can be found on our website or in the appendix to these operating instructions.

- The products are designed for operation on safety extra-low voltages (SELV).
- For the electrical connection of the products, the technical data of the products apply.
- Especially for passive probes (e.g. Pt100 etc.) in a two-wire circuit, the lead resistance of the supply line must be taken into account in order to correct measured value deviations (offset).
- If necessary, the lead resistance must be corrected in the subsequent electronics.
- Due to self-heating, the measuring current influences the measuring accuracy. Therefore, the measuring current should not be greater than 1 mA.

Wiring diagram

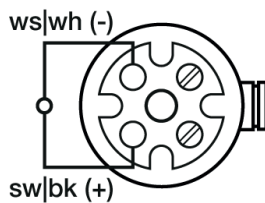

3.5. Maintenance

The product is maintenance-free. Repairs may only be carried out by the manufacturer or by qualified personnel.

3.6. Disposal

The product is to be classified as electrical and electronic equipment, so that it must be disposed of as electrical / electronic waste. Alternatively, you can return the product to us for proper disposal. The product should not be disposed of as household waste. Special treatment for special components may be legally mandatory and ecologically sensible. Please also observe the local legislation applicable to disposal.

4. Technical data and assembly instructions

Immersion thermocouple type J with J-Head

Order nr.803313 1111

Our immersion probe Thermoelment type J with J-head can be used in a temperature range up to +750 °C directly in contact with the medium or by using immersion sleeves. We offer brass or stainless steel immersion sleeves as well as mounting flanges and compression fittings made of different materials as accessories. Configure the probe according to your requirements and send us the order code.



Customizable options
C -Mounting length

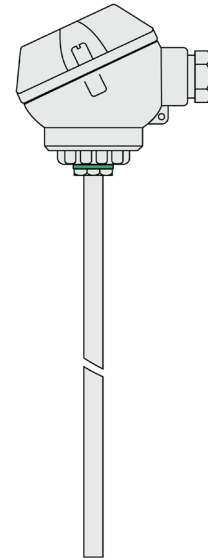

General Information	
Measuring range	-40 °C to +750 °C
Perm. (°C) conn. head	-40 °C to +100 °C
Accuracy	-40 °C to +375 °C: ±1,5 °C 375 °C to 750 °C: ±0,004 t according to DIN IEC 60584 Class 1
Response time	t63 / t99: information is available on request
Supply and output	
Measuring element	Thermocouple Type J
Measuring point	Measuring point isolated
Measurement signal	Thermovoltage
Ambient conditions	
Protection class	IP65 according DIN 40050
Humidity and moisture condensation resistance	according to application-specific qualification
Certificates and Standards	
Standards	DIN EN 61326-1:2013 DIN EN IEC 63000:2019-05
Directive	RoHS 2011/65/EU 2014/30/EU
Certificates	Certificate of suitability (on request)

Connection head	
Design	Form J
Material	Aluminium pressure die-casting
Color	RAL 9006 aluminium silver
W/H/Ø (mm)	50/60/48
Cable gland head	with strain relief
Clamping range (mm)	5 to 9
Ambient temperature max	+100 °C
Sensor unit	Fixed

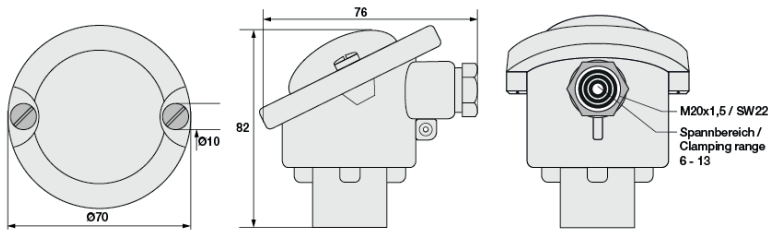

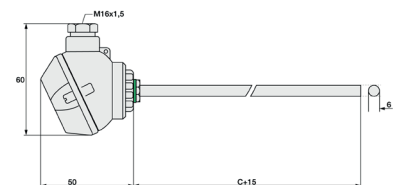
Protection sleeve		C - Mounting length			
Material	Stainless steel 1.4571 316Ti	Code	Length (mm)	Code	Length (mm)
		C0050	50 ¹⁾	C0250	250 ¹⁾
Ø (mm)	6 ²⁾	C0100	100 ¹⁾	C0300	300 ¹⁾
		C0150	150 ¹⁾	C0400	400 ¹⁾
		C0200	200 ¹⁾	C0500	500 ¹⁾
					

Other mounting lengths on request | ¹⁾Tolerance ± 1% | Please note: Mounting length = C + 15 mm | ²⁾ Tolerance ± 0,1 mm

Testo Sensor GmbH

+49 7653 96597-71

Testo-Straße 1
D-79853 Lenzkirch

webshop@testo-sensor.de

Managing Director: Prof. Burkart Knospe, Martin Arndt, Timo Löffler

Amtsgericht Freiburg HRB 706025 | Umsatzsteuer-ID.: DE274417683

Please find our whole temperature probe and transmitter portfolio in our webshop at: www.testo-sensor.shop

Your order code		Delivery and Assembly	
Order nr.	Mounting length	Assembly instructions	by means of existing protection sleeve, mounting flange, thermowell or compression fitting.
803313 1111	C_____	Delivery and Packaging	Probe, seperately packaged in PE bag

Important assembly advices

Measuring errors can occur due to heat dissipation to the environment. To keep these as small as possible, we recommend immersing the thermowell of your temperature sensor as deeply as possible into the medium to be measured during installation. The optimum installation depth should be 10-15 times the \varnothing of the thermowell or, when using a thermowell, the \varnothing of the thermowell. When installing in pipelines whose \varnothing does not have a sufficiently deep installation depth, you should install the probe either at an angle or in a pipe elbow. Make sure that there is sufficient space for the sensor to be removed. 1) Installation with sufficient installation depth 2) Installation at an angle with small pipe \varnothing 3) Not like this: Minimum installation depth not reached

Installation by means of compression fitting: Please tighten the union nut of the compression fitting by hand as far as it will go (clearly noticeable). For compression fittings with PTFE pressure ring, please make a 1/4 turn with a wrench suitable for the width across flats. These compression fittings can be used several times in this way. In the case of compression fittings with stainless steel cutting ring, the compression fitting connects to the protection tube. This connection is pressure resistant up to 40 bar. However, the compression fitting can only be used once. It must also be tightened more firmly. Please tighten it with 1 3/4 turns.

Mounting by means of mounting flange: Please make sure that the \varnothing of the mounting flange matches the \varnothing of the protective sleeve. For B-head fittings or very long protection sleeves, we recommend a stainless steel or aluminum mounting flange due to its stability.

Mounting by means of immersion sleeve (4): Please note that the \varnothing and the length of the immersion sleeve must be selected to match the installation situation so that the minimum immersion depth can be achieved. Since the sensor is not inserted directly into the medium, the response times are somewhat slower. The sensor should be selected so that the thermowell touches the bottom of the immersion sleeve and the air cushion around the thermowell is as small as possible. The use of thermal paste can improve the response times.

Please lay the cable with reserve loop (5) and in such a way that no water can penetrate the sensor head. This allows you to extend the sensor without disconnecting the electrical connection.

Technical drawing
Customizable options: C -Mounting length | All dimensions in mm

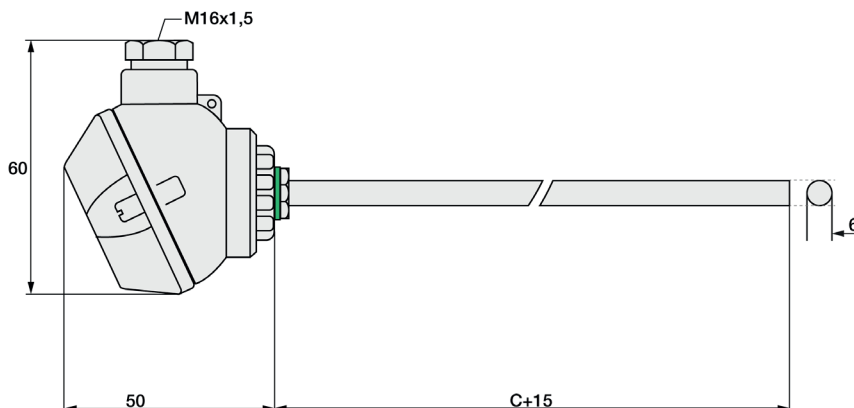

HP / CK 03.07.2024

Matching accessories: Thermocouple cables

Details of accessories can be found on our website.

Thermocouple cables											
Please select your desired cable first.											
Order code	Type	Color	IP	From (°C) ¹⁾	To (°C) ¹⁾	Outside material	Material strand	Ø (mm) ²⁾	Q (mm ²)	Color strand	Ω / m ⁴⁾
809300 1	Thermocouple cable	Type J ³⁾	IP67	-30	+90	PVC	PVC	3,8	0,22	bk, wt	2,5
809310 1	Thermocouple cable	Type J ³⁾	IP67	-50	+180	Silicone	FEP	3,6	0,22	bk, wt	2,5

Insulation resistance: ≥ 100 MOhm at min. 100 VDC | ¹⁾per. °C range | ²⁾Tolerance ± 0.2 mm | ³⁾ Color according to IEC 584 | ⁴⁾per thermocouple

Now please select the length and add the code to the article no. of the cable.					
Length (m)	1	2	5	10	20
Code	010	020	050	100	200

Please append these digits to the part number of your desired cable.

Matching accessories: Connector

Connector			
Picture	Code	Feature	Technical drawing
	809140 1000	Mini-TC connector Type J bk	
	809100 1000	Mini-TC coupling Type J bk	
	809150 1000	TC connector Type J bk	
	809110 1000	TC coupling Type J bk	

Other connectors available on request

HP / CK 03.07.2024

Matching accessories: Mounting flange

Steel flange	
Article no.	809500 1XXX
Material	Stainless Steel
Fixing	3 x Ø 4,5 mm drill holes
Now please select the size of the hole and append the last digits to your order number.	
A - Hole (mm)	Code
6	060
9	090
10	100
15	150
Your order code 809500 1_ _ _	

Aluminium flange	
Article no.	809500 2XXX
Material	Aluminium
Fixing	2 x Ø 4,5 mm drill holes
Now please select the size of the hole and append the last digits to your order number.	
A - Hole (mm)	Code
6	060
11	110
Your order code 809500 2_ _ _	

Plastic flange	
Article no.	809500 4XXX
Material	Plastic
Fixing	2 x Ø 4,5 mm drill holes
Now please select the size of the hole and append the last digits to your order number.	
A - Hole (mm)	Code
6	060
12	120
Your order code 809500 4_ _ _	

HP / CK 03.07.2024

Testo Sensor GmbH

+49 7653 96597-71
 Testo-Straße 1
 D-79853 Lenzkirch

Managing Director: Prof. Burkart Knospe, Martin Arndt, Timo Löffler
 webshop@testo-sensor.de
 Amtsgericht Freiburg HRB 706025 | Umsatzsteuer-ID.: DE274417683
 Please find our whole temperature probe and transmitter portfolio in our webshop at: www.testo-sensor.shop

Matching accessories: Immersion sleeves

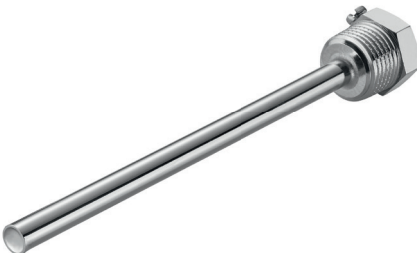
Brass immersion sleeve R1/2 "			
	Article no.	809520 10XX	Code
	Temp. max	+150 °C	05
	Pressure proof up to	10 bar	10
	Material	Nickel plated	15
	Process connection	R1/2 "	20
	Wrench size	22	25
	Ø Inside / Outside (mm)	6,5 / 8	30
	Scope of delivery	Immersion sleeve, packed in PE bag	40
	Order code	809520 10	--

Please attach the code for the mounting length.

Technical drawing

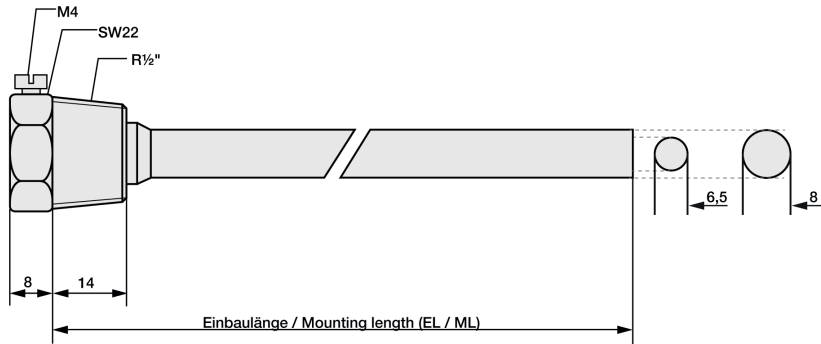

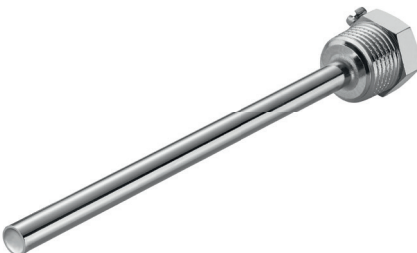
Stainless steel immersion sleeve G1/2 "			
	Article no.	809520 20XX	Code
	Temp. max	+600 °C	05
	Pressure proof up to	40 bar	10
	Material	Stainless steel 1.4571 316TI	15
	Process connection	G1/2 "	20
	Wrench size	22	25
	Ø Inside / Outside (mm)	6,2 / 9	30
	Scope of delivery	Immersion sleeve, packed in PE bag	40
	Your order code	809520 20	--

Please attach the code for the mounting length.

Technical drawing

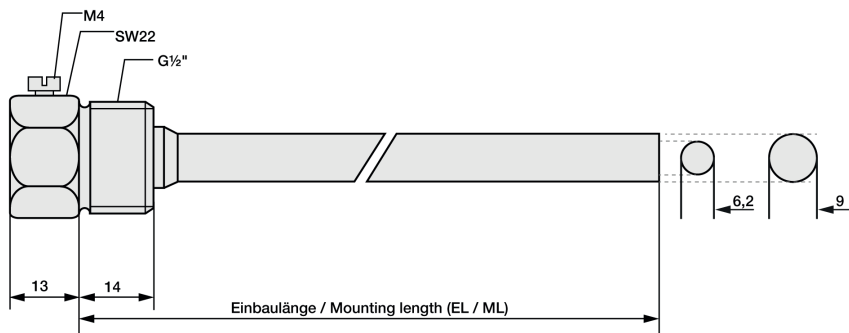

HP / CK 03.07.2024

Testo Sensor GmbH

+49 7653 96597-71
 Testo-Straße 1
 D-79853 Lenzkirch

Managing Director: Prof. Burkart Knospe, Martin Arndt, Timo Löffler
 Amtsgericht Freiburg HRB 706025 | Umsatzsteuer-ID.: DE274417683

Please find our whole temperature probe and transmitter portfolio in our webshop at: www.testo-sensor.shop

Matching accessories: Immersion sleeves

Immersion sleeve G1/2 " with cable gland					
Article no.	809520 60XX	Compression fitting		Code	Mounting length (mm)
Temp. max	+600 °C	Temp. max	100 °C	05	50
pressure proof until	40 bar	Material	Plastic	10	100
Material	Stainless steel 1.4571 316TI	Screw	M12 x 1,5	15	150
Process connection	G1/2 "	Clamping range (mm)	3 bis 6,5	20	200
Wrench size	22			25	250
Scope of delivery	Immersion sleeve, packed in PE bag	Cable gland	strain relief	30	300
				40	400
Your order code	809520 60			--	--



Please attach the code for the mounting length.

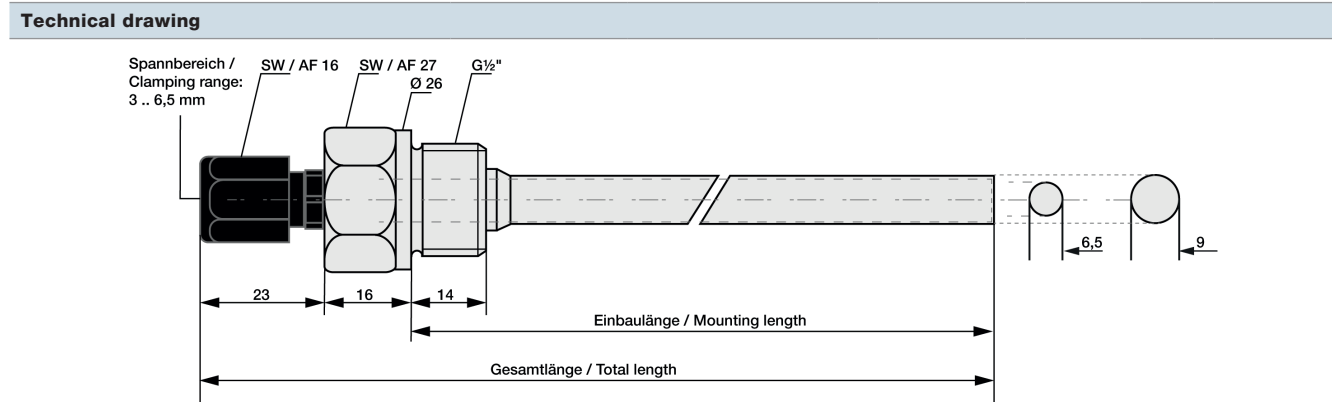

HP / CK 03.07.2024

Matching accessories: Compression fittings

Compression fitting with PTFE clamping ring

Compression fittings with PTFE clamping ring can be used several times. They are only pressure-tight up to 10 bar. For assembly, please tighten the connecting nut of the compression fitting by hand as far as it will go (clearly noticeable) by hand. With a wrench suitable for the width across flats, please make a 1/4 turn for compression fittings with PTFE pressure ring.

	Article no.	809610 2XXX	Code	I - Ø Inside (mm)	Code	J - Process connection
	Temp. max	+260 °C	0	1	27	M6x1 ¹⁾
	Pressure proof up to	10 bar	1	1,5	28	M8x1 ¹⁾
	Material	Stainless steel 1.4571 316TI	3	3	22	M10x1
	Material clamping ring	PTFE	6	6	14	G1/8 "
	Scope of delivery	Compression fitting, packed in PE bag			12	G1/4 "
					11	G1/2 "
Your order code	809610 2	-	-	-	-	

Append the code for Ø Inside & process connection to the article no. | ¹⁾ not available for Ø Inside (I) 6 mm

Dimensions for technical drawing

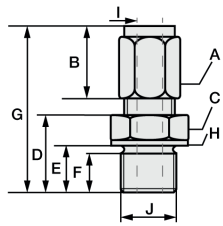

I	J	A	B	C	D	E	F	G	H
1	M6x1 ¹⁾	SW10	13	SW12	13	9	8	31	Ø10
1,5	M8x1 ¹⁾	SW10	13	SW12	13,5	9,5	8	31	Ø11,8
3	M10x1	Ø 1,5 & 3: SW10 Ø 6: SW12	13	SW14	13,5	9,5	8	32	Ø13,8
6	G1/8 "	Ø 1,5 & 3: SW10 Ø 6: SW12	13	SW14	13,5	9,5	8	32	Ø13,8
	G1/4 "	Ø 1,5 & 3: SW10 Ø 6: SW12	13	SW19	20	14	12	38,5	Ø18
	G1/2 "	Ø 1,5 & 3: SW10 Ø 6: SW12	13	SW27	23	17	14	38,5	Ø26

All dimensions in mm | ¹⁾ not available for Ø Inner (I) 6 mm

Compression fitting with stainless steel cutting ring

In compression fittings with stainless steel cutting ring, the compression fitting connects with the protective sleeve. This connection is pressure-resistant up to 40 bar. Therefore, these compression fittings can also only be used once and must be tightened more firmly. For assembly, please tighten the union nut of the compression fitting by hand as far as it will go (clearly noticeable). With a wrench suitable for the wrench size, please make 1 3/4 turns for compression fittings with stainless steel cutting ring.

	Article no.	809610 1XXX	Code	I - Ø Inside (mm)	Code	J - Process connection
	Temp. max	+800 °C	1	1,5	27	M6x1 ¹⁾
	Pressure proof up to	40 bar	3	3	28	M8x1 ¹⁾
	Material	Stainless steel 1.4571 316TI	6	6	22	M10x1
	Material clamping ring	Stainless steel 1.4571 316TI			14	G1/8 "
	Scope of delivery	Cutting ring screw fitting, packed in PE bag			12	G1/4 "
					11	G1/2 "
Your order code	809610 1	-	-	-	-	

Append the code for Ø Inside & process connection to the article no. | ¹⁾ not available for Ø Inside (I) 6 mm

Dimensions for technical drawing

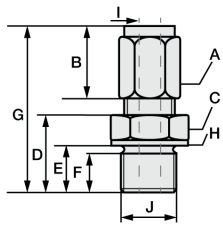

I	J	A	B	C	D	E	F	G	H
1,5	M6x1 ¹⁾	SW10	13	SW12	13	9	8	31	Ø10
3	M8x1 ¹⁾	SW10	13	SW12	13,5	9,5	8	31	Ø11,8
6	M10x1	Ø 1,5 & 3: SW10 Ø 6: SW12	13	SW14	13,5	9,5	8	32	Ø13,8
	G1/8 "	Ø 1,5 & 3: SW10 Ø 6: SW12	13	SW14	13,5	9,5	8	32	Ø13,8
	G1/4 "	Ø 1,5 & 3: SW10 Ø 6: SW12	13	SW19	20	14	12	38,5	Ø18
	G1/2 "	Ø 1,5 & 3: SW10 Ø 6: SW12	13	SW27	23	17	14	38,5	Ø26

All dimensions in mm | ¹⁾ not available for Ø Inner (I) 6 mm

HP / CK 03.07.2024

5. Characteristics

HP / CK 03.07.2024

Testo Sensor GmbH

Testo-Straße 1
D-79853 Lenzkirch

+49 7653 96597-71
webshop@testo-sensor.de
Please find our whole temperature probe and transmitter portfolio in our webshop at: www.testo-sensor.shop

Managing Director: Prof. Burkart Knospe, Martin Arndt, Timo Löffler
Amtsgericht Freiburg HRB 706025 | Umsatzsteuer-ID.: DE274417683

Characteristic Thermocouple Type J

Measuring range: -40 °C to +750 °C

Accuracy class Thermocouple Type J according DIN IEC 60584	
Class	Formula
Cl. 1	-40 °C to +375 °C: $\pm 1,5 \text{ }^\circ\text{C}$ +375 °C to +750 °C: $\pm 0,004 t $
Cl. 2	-40 °C to +333 °C: $\pm 2,5 \text{ }^\circ\text{C}$ +333 °C to +750 °C: $\pm 0,0075 t $

Example values		
Value @ T = 100 °C	Value @ T = 500 °C	Value @ T = 700 °C
$\pm 1,5 \text{ }^\circ\text{C}$	$\pm 2,00 \text{ }^\circ\text{C}$	$\pm 2,8 \text{ }^\circ\text{C}$
$\pm 2,5 \text{ }^\circ\text{C}$	$\pm 3,75 \text{ }^\circ\text{C}$	$\pm 5,25 \text{ }^\circ\text{C}$

Type J		Max. Tol. \pm in °C**		Type J		Max. Tol. \pm in °C**		Type J		Max. Tol. \pm in °C**		Type J		Max. Tol. \pm in °C**	
T in °C	EMF* in μV	Cl. 1	Cl. 2	T in °C	EMF* in μV	Cl. 1	Cl. 2	T in °C	EMF* in μV	Cl. 1	Cl. 2	T in °C	EMF* in μV	Cl. 1	Cl. 2
-210	-8.095			150	8.010	1,5	2,5	510	27.953	2,0	3,8	870	49.898		
-200	-7.890			160	8.562	1,5	2,5	520	28.516	2,1	3,9	880	50.622		
-190	-7.659			170	9.115	1,5	2,5	530	29.080	2,1	4,0	890	51.251		
-180	-7.403			180	9.669	1,5	2,5	540	29.647	2,2	4,1	900	51.877		
-170	-7.123			190	10.224	1,5	2,5	550	30.216	2,2	4,1	910	52.500		
-160	-6.821			200	10.779	1,5	2,5	560	30.788	2,2	4,2	920	53.119		
-150	-6.500			210	11.334	1,5	2,5	570	31.362	2,3	4,3	930	53.735		
-140	-6.159			220	11.889	1,5	2,5	580	31.939	2,3	4,4	940	54.347		
-130	-5.801			230	12.445	1,5	2,5	590	32.519	2,4	4,4	950	54.956		
-120	-5.426			240	13.000	1,5	2,5	600	33.102	2,4	4,5	960	55.561		
-110	-5.037			250	13.555	1,5	2,5	610	33.689	2,4	4,6	970	56.164		
-100	-4.633			260	14.110	1,5	2,5	620	34.279	2,5	4,7	980	56.763		
-90	-4.215			270	14.665	1,5	2,5	630	34.873	2,5	4,7	990	57.360		
-80	-3.786			280	15.219	1,5	2,5	640	35.470	2,6	4,8	1.000	57.953		
-70	-3.344			290	15.773	1,5	2,5	650	36.071	2,6	4,9	1.010	58.545		
-60	-2.893			300	16.327	1,5	2,5	660	36.675	2,6	5,0	1.020	59.134		
-50	-2.431			310	16.881	1,5	2,5	670	37.284	2,7	5,0	1.030	59.721		
-40	-1.961	1,5	2,5	320	17.434	1,5	2,5	680	37.896	2,7	5,1	1.040	60.307		
-30	-1.482	1,5	2,5	330	17.986	1,5	2,5	690	38.512	2,8	5,2	1.050	60.890		
-20	-995	1,5	2,5	340	18.538	1,5	2,6	700	39.132	2,8	5,3	1.060	61.473		
-10	-501	1,5	2,5	350	19.090	1,5	2,6	710	39.755	2,8	5,3	1.070	62.054		
0	0	1,5	2,5	360	19.642	1,5	2,7	720	40.382	2,9	5,4	1.080	62.634		
10	507	1,5	2,5	370	20.194	1,5	2,8	730	41.012	2,9	5,5	1.090	63.214		
20	1.019	1,5	2,5	380	20.745	1,5	2,9	740	41.645	3,0	5,6	1.100	63.792		
30	1.537	1,5	2,5	390	21.297	1,6	2,9	750	42.281	3,0	5,6	1.110	64.370		
40	2.059	1,5	2,5	400	21.848	1,6	3,0	760	42.919			1.120	64.948		
50	2.585	1,5	2,5	410	22.400	1,6	3,1	770	43.559			1.130	65.525		
60	3.116	1,5	2,5	420	22.952	1,7	3,2	780	44.203			1.140	66.102		
70	3.650	1,5	2,5	430	23.504	1,7	3,2	790	44.848			1.150	66.679		
80	4.187	1,5	2,5	440	24.057	1,8	3,3	800	45.494			1.160	67.255		
90	4.726	1,5	2,5	450	24.610	1,8	3,4	810	46.141			1.170	67.831		
100	5.269	1,5	2,5	460	25.164	1,8	3,5	820	46.786			1.180	68.406		
110	5.814	1,5	2,5	470	25.720	1,9	3,5	830	47.431			1.190	68.980		
120	6.360	1,5	2,5	480	26.276	1,9	3,6	840	48.074						
130	6.909	1,5	2,5	490	26.834	2,0	3,7	850	48.715						
140	7.459	1,5	2,5	500	27.393	2,0	3,8	860	49.353						

*Thermoelectric voltage (EMF) in μV

**Maximum tolerance according DIN IEC 60584

HP / CK 03.07.2024

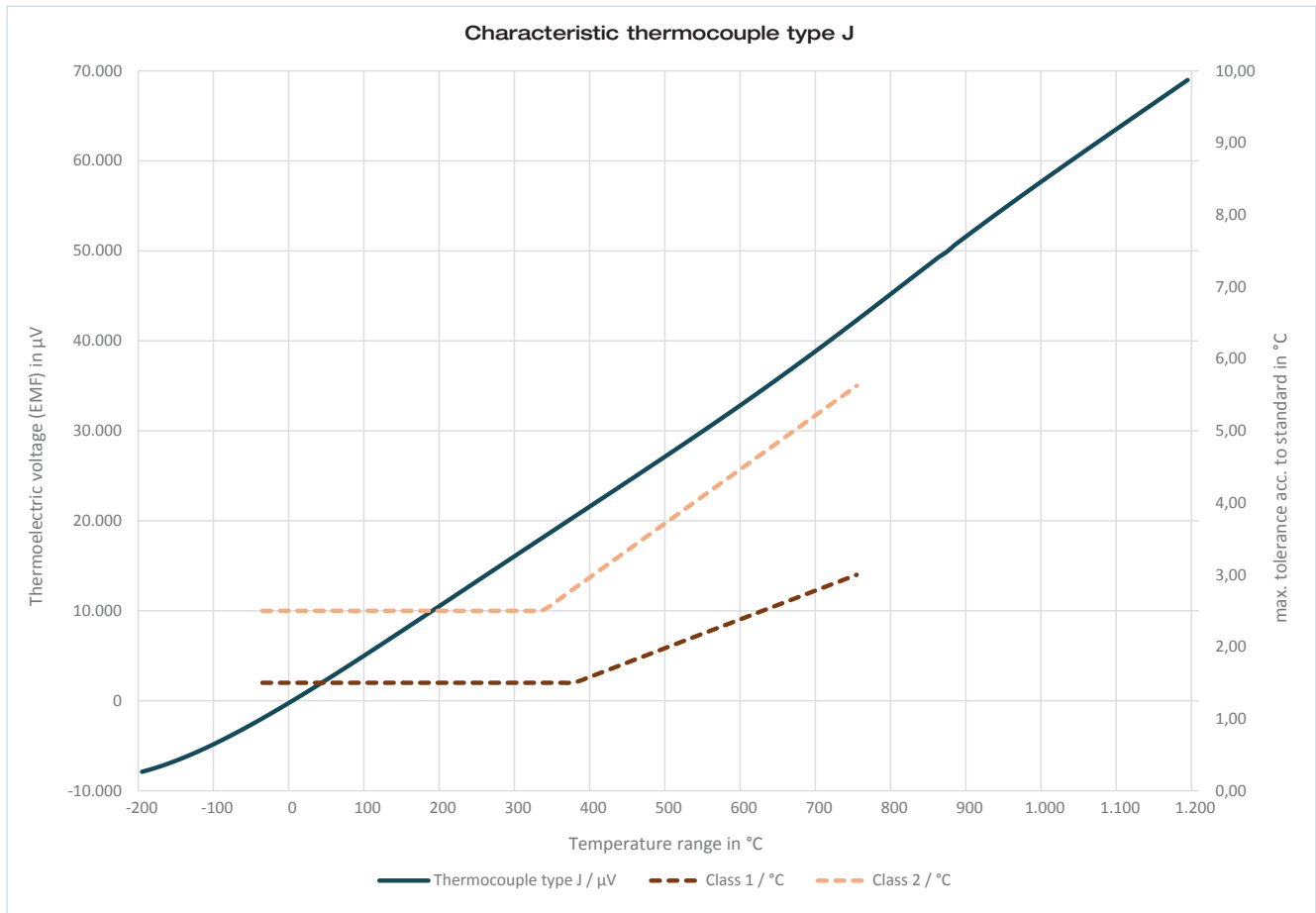

HP / CK 03.07.2024

The standard specifies measuring ranges for thermocouples in which the respective measuring accuracy of the tolerance class applies. For use outside this specified measuring range, it is not possible to specify the measuring accuracy. If the thermocouple is operated outside the specified measuring range of its respective tolerance class, irreversible damage to the thermocouple may occur, which will result in a measurement deviation (even within the specified range). Use beyond the measuring range of the tolerance class represents misuse and leads to a loss of warranty.

Testo Sensor GmbH

+49 7653 96597-71
 Testo-Straße 1
 D-79853 Lenzkirch
 webshop@testo-sensor.de

Managing Director: Prof. Burkart Knospe, Martin Arndt, Timo Löffler
 Amtsgericht Freiburg HRB 706025 | Umsatzsteuer-ID.: DE274417683
 Please find our whole temperature probe and transmitter portfolio in our webshop at: www.testo-sensor.shop

Testo Sensor GmbH
Testo-Strasse 1
79853 Lenzkirch

Phone: +49 7653 96597 0
Fax: +49 7653 96597 99
E-mail: info@testo-sensor.de

Handelsregister: HRB 706025
Registergericht: Amtsgericht Freiburg

HP / CK 03.07.2024

All rights reserved. Changes to the documents are not authorised.
We reserve the right to make technical changes.
Please read the operating instructions before starting any work.