

# User Manual

## Outdoor Temperature Transmitter Basic 0-10 V

Article number: 807002 0013

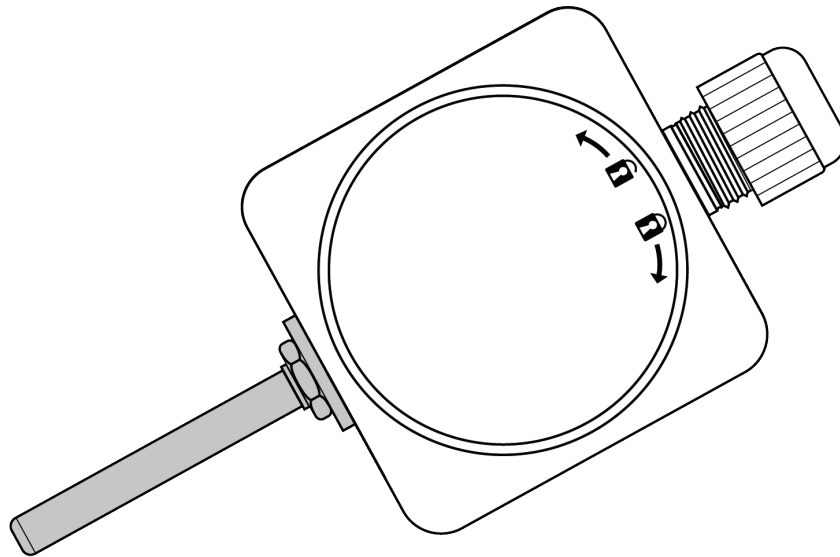

RL / KS / 28.06.2024

All rights reserved. Changes to the documents are not allowed. Please read the operating instructions before starting any work and keep them carefully and to hand.

### Testo Sensor GmbH

Testo-Straße 1  
D-79853 Lenzkirch

+49 7653 96597-71

webshop@testo-sensor.de

Please find our whole temperature probe and transmitter portfolio in our webshop at: [www.testo-sensor.shop](http://www.testo-sensor.shop)

Managing Director: Prof. Burkart Knospe, Martin Arndt, Timo Löffler

Amtsgericht Freiburg HRB 706025 | Umsatzsteuer-ID.: DE274417683

# 1. Table of content

- 1. General ..... 3
  - 1.1. Security..... 3
  - 1.2. Intended use..... 3
  - 1.3. Personnel qualification..... 3
  - 1.4. Signage, safety labels, type plate..... 3
- 2. Transport, packaging and storage..... 4
- 3. Commissioning..... 4
  - 3.1. Assambly..... 4
  - 3.2. Requirements for achieving the protection class (IP 65)..... 4
  - 3.3. Drilling template ..... 4
  - 3.4. Pin assignment and configuration of input and output by means of DIP switches..... 4
  - 3.5. Maintenance ..... 4
  - 3.6. Disposal ..... 4
- 4. Technical data and assembly instructions..... 5

RL / KS / 28.06.2024

## 1. General

- The product described in the operating instructions is manufactured according to the current state of the art. All components are subject to strict quality and environmental criteria during manufacture. Our management systems are certified according to ISO 9001 and ISO 14001. The GTC in the sales documents apply.
- These operating instructions are an important part of the product. It must be available to qualified personnel and must be carefully read and understood before starting any work. Please be sure to comply with all the safety and handling instructions given. In particular, observe the local accident prevention regulations and general safety regulations applicable to the area of use of the unit.
- The manufacturer's liability expires in the event of damage caused by improper use, non-observance of the instructions, use of insufficiently qualified personnel and unauthorised modifications to the unit
- Subject to technical changes.

### 1.1. Security

**WARNING! Before installation, commissioning and operation, please make absolutely sure that the correct product has been selected with regard to design and specific measuring conditions. Failure to do so may result in serious personal injury and/or damage to property.**

- The selection of the products and, in particular, the determination of their suitability for a specific purpose are the sole responsibility of the purchaser, who must also ensure that incorrect planning, operation or installation does not cause any further damage and that compliance with the relevant construction and safety guidelines is observed and guaranteed.
- No liability or warranty is expressly accepted for damage caused by incorrect planning, operation, installation or malfunction of the units.
- The technical data and connection conditions in the supplied installation and operating instructions apply exclusively.
- Please contact us if you need to know more about the specification you require.

### 1.2. Intended use

- For the intended use of the product, please refer to the technical data and the commissioning instructions in the operating instructions. The unit is designed and built exclusively for the intended use described there and may only be used accordingly. The technical specifications must be observed. Claims due to improper use are excluded.
- This device must not be used for safety-relevant tasks, such as monitoring or protecting persons against danger or injury, as an emergency stop switch on systems or machines, etc.
- This product has been developed, qualified and manufactured to the highest quality standards. Application-specific environmental or stress conditions can influence the behaviour and lead to deviations from the specifications in the data sheet. To avoid this, we recommend application-specific advice.

**Application-specific environmental or stress conditions can be in particular:**

- Ingress of humidity, which can lead to falsification of measured values
- Vibration, which causes high acceleration forces
- UV irradiation, which can lead to embrittlement of the cable insulation
- Tensile forces acting on the cable, which can damage the probe's internal structure
- Insufficient thermal coupling to the measured medium, with increased response times as a result
- impact with excessively high temperatures, which can change or destroy the built-in measuring resistor or electronic components
- corrosion at the cable ends or the connector contacts, so that measured value falsifications can occur.

### 1.3. Personnel qualification

**WARNING! - Risk of injury due to insufficient professional qualification! Improper handling can lead to considerable personal injury and damage to property.**

- The activities described in these operating instructions may only be carried out by adequately qualified personnel. Special operating conditions may require additional, appropriate knowledge, e.g. about aggressive media, possible dangers or country-specific regulations, standards or guidelines. Please keep unqualified personnel away from the danger areas.

### 1.4. Signage, safety labels, type plate

Our products are marked with a label as follows. (Exemplary representation)

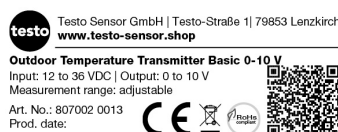

## 2. Transport, packaging and storage

### 2.1. Transport, packaging and storage

- Transport: Please inspect the unit for any transport damage immediately after delivery. Please notify us immediately of any obvious damage.
- Packaging: Please remove the packaging only immediately before assembly and keep it, as the packaging provides optimum protection during transport.
- Storage: Please refer to the data sheet for permissible temperature and ambient humidity conditions.

#### The following influences are to be avoided:

- Direct sunlight or proximity to hot objects.
- Mechanical vibration, mechanical shock (hard impact)
- Exposure to soot, steam, dust or corrosive gases
- Explosive environment, flammable atmospheres

### 2.2. Original packaging

**Please store the unit in the original packaging in a place that meets the conditions listed above. If the original packaging is not available, please pack and store the unit as follows**

- Wrap the unit in an antistatic plastic sheet.
- Place the unit with the insulation material in the packaging.
- For longer storage (more than 30 days), add a bag of desiccant to the packaging.

## 3. Commissioning

### 3.1. Assembly

- The units may only be connected in a de-energised state, only to safety extra-low voltages and only by suitably qualified personnel. The installation instructions in the data sheet must be observed.
- Please observe the safety regulations of the VDE, the federal states, their monitoring bodies, the TÜV and the local EVU.
- Please observe EMC guidelines to prevent damage, faults on the unit or measured value deviations.

### 3.2. Requirements for achieving the protection class (IP 65)

- Only use the cable gland in the specified clamping range (select the cable Ø to match the cable gland).
- Do not use the lower clamping area when using very soft cable types.
- Only use round cables (a slightly oval cross-section may also be suitable).
- Do not twist the cable.
- Multiple opening/closing is possible, but can have a negative effect on the protection class.
- For cables with pronounced cold flow behaviour, please tighten the screw connection if necessary.

### 3.3. Drilling template

You will find the drilling template, if available, in the technical data. .

### 3.4. Pin assignment and configuration of input and output by means of DIP switches

- The units are designed for operation on safety extra-low voltages (SELV). For the electrical connection of the units, the technical data of the units apply. You will find the pin assignment and the configuration of input and output by means of DIP switches in our data sheet on the website.
- The output voltage follows linearly to the temperature signal applied to the input and provides a proportional output signal of 0 -10 V.
- Applying the power supply to the output will destroy the unit.
- With the transmitter with 4...20 mA, display and evaluation elements are connected in series in the current loop.
- The transmitter limits the flowing current depending on the input signal. The 4 mA are used for the transmitter's own power supply.

### 3.5. Maintenance

The product is maintenance-free. Repairs may only be carried out by the manufacturer or by qualified personnel.

### 3.6. Disposal

The product is to be classified as electrical and electronic equipment, so that it must be disposed of as electrical / electronic waste. Alternatively, you can return the product to us for proper disposal. The product should not be disposed of as household waste. Special treatment for special components may be legally mandatory and ecologically sensible. Please also observe the local legislation applicable to disposal.

## Testo Sensor GmbH

Testo-Straße 1  
D-79853 Lenzkirch

+49 7653 96597-71

✉ [webshop@testo-sensor.de](mailto:webshop@testo-sensor.de)

🌐 Please find our whole temperature probe and transmitter portfolio in our webshop at: [www.testo-sensor.shop](http://www.testo-sensor.shop)

Managing Director: Prof. Burkart Knospe, Martin Arndt, Timo Löffler

Amtsgericht Freiburg HRB 706025 | Umsatzsteuer-ID.: DE274417683

## 4. Technical data and assembly instructions

### Outdoor Temperature Transmitter Basic 0-10 V

Article number: 807002 0013

Our rugged and reliable outdoor temperature transmitter is an ideal choice for outdoor areas that require a compact, shockproof and easy-to-install temperature monitoring solution. Thanks to its fixed Pt1000 RTD sensor, temperature is measured accurately. With the standardized 0-10 V signal at the output, it can be seamlessly integrated into existing heating systems and control systems. It is characterized by its high measurement accuracy and long-term service life, even under difficult operating conditions. The integrated alarm functions, including sensor break, sensor short-circuit and measuring range monitoring, ensure correct temperature measurement and transmission and provide additional safety. The transmitter can be parameterized quickly and easily using DIP switches.



<b>Special features</b>	
<b>Inputs and outputs</b>	<p>werkzeugfreie Montage durch innovativen Drehdeckelverschluss tool-free assembly due to innovative rotary lid lock</p> <p>Messelement: Pt 1000 Measuring element: Pt 1000</p> <p>Ausgang: 0 - 10 V Output: 0 - 10 V</p> <p>einfach parametrieren mit DIP-Schaltern easy to parameterise with DIP switches</p>
Input: Pt1000 resistance sensor, permanently installed output: 0 to 10 V	
<b>Accuracy and Long-term stability</b>	
Accuracy: high measuring accuracy Long-term stability: long service life with flexible application possibilities	
<b>Alarm function</b>	
Sensor break monitoring Sensor short-circuit monitoring Measuring range monitoring	
<b>Design</b>	
Compact, robust, vibration and shock resistant design	
<b>Parametrization</b>	
Simple and super-fast parameterization thanks to preset dip switches	

Input			
Measuring element	Norm	Configurable measuring range	Accuracy
Pt1000	IEC 60751	-200 °C to +850 °C   -328 °F to +1562 °F	±0.3 °C + 0.1 % of the measuring span
Connection type	2-wire (permanently installed)		

Output		Circuit diagram Output	
Output type	analog, temperature linear for RTD		
Output signal	0 to 10 V		
Parametrization / Scaling	Configurable via DIP-Switch		
Resolution	16 bit dac		
Accuracy (°C)	0,1		
Load	500 Ω at 24 VDC		
Connection type	3-wire and 4-wire		

RL / KS / 28.06.2024

Sensor monitoring & sensor error		Measured values outside the measuring range	
Sensor failure effects	according to NAMUR NE43	Sensor Status	0 - 10 V
<b>Alarms</b>		Min. measured value	0 V
Sensor error	0 - 10 V	Max. measured value	10 V
Sensor Status	11 V	Underrange	0 V
Sensor short circuit	11 V	Overrange	10,5 V

Time response		Accuracy and stability	
Closing time (s)	≤ 5	<b>Cold junction compensation</b>	
Signal attenuation (s)	0 – 30	Cold Junction Compensation	±0,3 – 0,5 °C (NTC 5K)
Measuring cycle (s)	<0,25 ( <4 Hz )	Temperature influence	±0,01 °C per °C
Response time	Depending on sensor type		

Ambient conditions	
Ambient Temperatur	Storage: -20 °C to +70 °C (housing) Operating: -20 °C to +70 °C (housing)
Humidity (%rH)	0 to 98 (non-condensing)
Protection	Housing IP65

EMC	
Standard	Directive: 2014/30/EU   Harmonized standards: EN 61326-1:2013

Type	
Dimensions (mm)	135 x 60 x 34 (see drawing)
Weight (g)	75
Material   Flammability	ABS white RAL 9010 UV resistant, RoHS compliant
Mounting	Enclosed mounting kit (housing)
Connection	Single wires, max. 1,5 mm <sup>2</sup> , AWG 16
<b>Protection sleeve</b>	
Material	Stainless steel 1.4404   316L
Diameter (mm)	6
Mounting length (mm)	50

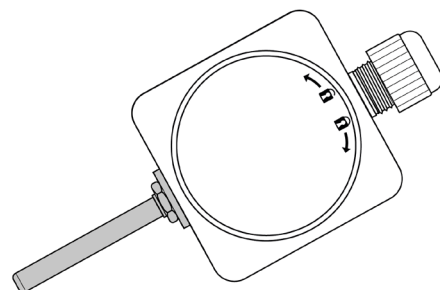

Factory configuration		Factory settings	
Input	Pt1000 fixed	Ausstemperaturtransmitter (RTD Sensoren) Werkseinstellungen: Sensor Pt1000 Skalierung: -20 .. 50 °C	
Scaling	-20 °C to +50 °C	Outdoor temperature transmitter (RTD sensors) Factory settings: Sensor Pt1000 Scaling: -20 ... 50 °C	

General data	
Isolation	none
Supply Voltage (VDC)	12 to 36, polarity protected

Delivery	
Transmitter, Instruction manual, individually packed in PE bag	

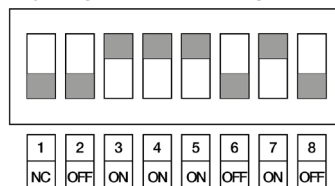

Matching accessories	
DIN rail power supply	On request
Table power supply	On request
Matching Sun Protection	in the Webshop: testo-sensor.shop
Matching connection cables	in the Webshop: testo-sensor.shop

RL / KS / 28.06.2024

**Technical drawing**

**Front view**

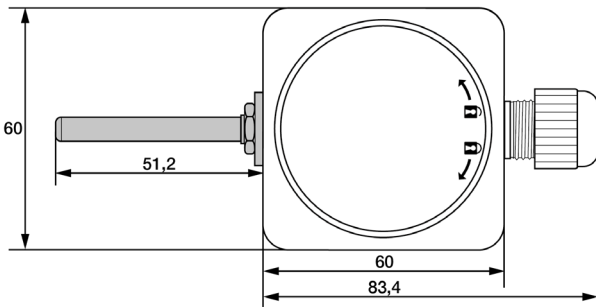

**Rear view**

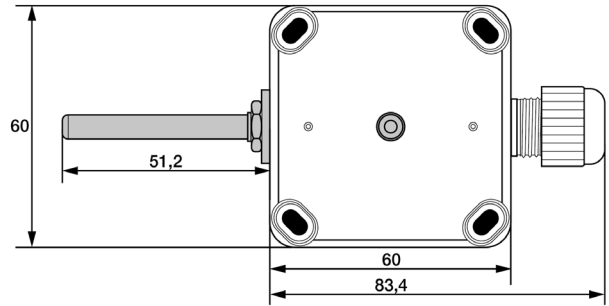

**Side view**

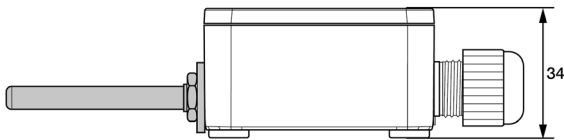

All dimensions in mm

**Pin assignment input and output**

<b>Input</b>	Pt1000 fest verbaut	<b>Output</b>	<b>Output 0-10V 3w</b>
	Pt1000 fixed mounted		<b>Output 0-10V 4w</b>
			4 <input type="radio"/> 24V+ 3 <input type="radio"/> 24V-   Out 10V- 2 <input type="radio"/> Out 10V+ 1 <input type="radio"/> Out 10V+
			4 <input type="radio"/> 24V+ 3 <input type="radio"/> 24V- 2 <input type="radio"/> Out 10V- 1 <input type="radio"/> Out 10V+

**Parametrization**

Einstellen der Skalierung via DIP-Schalter  
Setting the scaling range via DIP switch

**Setting the input signal**

With the DIP switches of the transmitter you can configure the transmitter according to your needs. Please just leave the DIP switches 1-4 in position. Switches 5-8 are used to set the scaling and the measuring range. Please refer to the adjacent table for the exact configuration.

**Setting the measuring range (0 .. 250 °C)**

on	on	on	on	Scaling Range
Bit 5	Bit 6	Bit 7	Bit 8	
on	on	on	on	0 .. +50°C
off	on	on	on	0 .. +100°C
on	off	on	on	0 .. +150°C
off	off	on	on	0 .. +200°C
on	on	off	on	0 .. +250°C
off	on	off	on	0 .. +400°C
on	off	off	on	0 .. +600°C
off	off	off	on	0 .. +800°C
on	on	on	off	0 .. +1.000°C
off	on	on	off	0 .. +1.200°C
on	off	on	off	-20 .. +50°C
off	off	on	off	-20 .. +120°C
on	on	off	off	-30 .. +70°C
off	on	off	off	-50 .. +50°C
on	off	off	off	-50 .. +150°C
off	off	off	off	-200 .. +50°C

RL / KS / 28.06.2024

**Mounting**

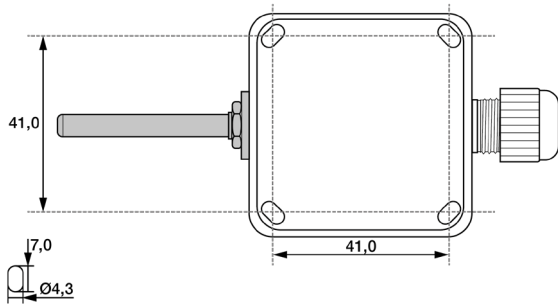

Thanks to the four slotted holes, the housing can be easily mounted on the wall. The openings for the screws are located outside the protective space for the electronics, so no sealing is required. With the cable compression glands, sealing to the probe or data cable is guaranteed even for different diameters.

Mounting material for the installation of the transmitter (screws and dowels) are included with the transmitter as free accessories. A large assortment of temperature probes and connecting cables is also available as an option.

Important: To prevent measuring errors, the connecting screws for fastening the connecting cable must be firmly tightened.

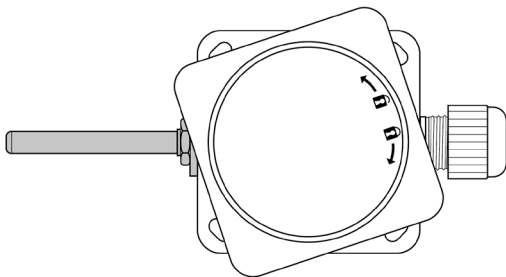

Open the rotary cover.

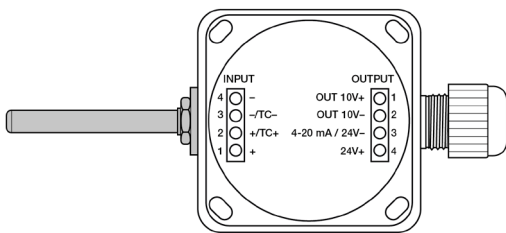

You can parameterize your temperature transmitter and set the scaling via the DIP switches. Please use the information from the parameterization table.

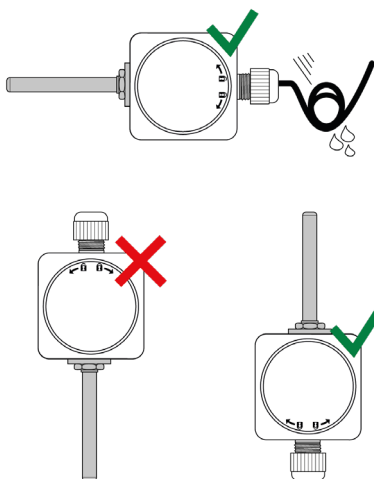

Mount your outdoor probe with sufficient distance to vents, windows or doors and preferably on the north wall, alternatively on west or east wall of the building. Avoid direct sunlight and rain. Use Sun Protection if necessary. Please lay the cables downwards so that rainwater can drip off in a defined way. Please consider the permissible ambient conditions during installation.

RL / KS / 28.06.2024



**Testo Sensor GmbH**  
**Testo-Strasse 1**  
**79853 Lenzkirch**

**Telefon: +49 7653 96597 0**  
**Telefax: +49 7653 96597 99**  
**E-Mail: [info@testo-sensor.de](mailto:info@testo-sensor.de)**

**Handelsregister: HRB 706025**  
**Registergericht: Amtsgericht Freiburg**

RL / KS / 28.06.2024

All rights reserved. Changes to the documents are not authorised.  
We reserve the right to make technical changes.  
Please read the operating instructions before starting any work.