

Room humidity transmitter design 0-10 V

Article number: 801110 6023

Our room humidity transmitter design with a voltage output of 0-10 V and the Frija1 housing can be easily mounted using screws. This device measures the humidity and optionally the temperature. The Design 0-10 V room humidity transmitter is ideal for the precise measurement of humidity and temperature in indoor spaces such as offices, supermarkets and schools.



Supply and output	
Output	0 - 10 V
Power consumption	< 1,1 VA / 24 V DC; < 2,2 VA / 24 V AC
Voltage supply	24 V AC (± 20 %) 15 - 36 V DC
Connection type	See connection diagrams

General information	
Load resistance	RI > 5 kOhm
Sensors	Digital humidity sensor, optionally with integrated temperature sensor

Humidity	
Measuring element humidity	Digital humidity sensor (low hysteresis, high long-term stability)
Measuring range humidity	0 % RH to 100 % RH
Output humidity	0-10 V
Accuracy humidity	± 2.0 % (20 % RH to 80 % RH) at +25 °C, otherwise ± 3.0 %
Long-term stability	± 1 % / year

Temperature	
Measuring element Temperature	Pt1000, DIN EN 60751, Class B
Measuring range temperature	0 °C to +50 °C
Output temperature	0 - 10 V
Accuracy temperature	typically ± 0.2 K at +25 °C

Configurable options
M - Measured variable

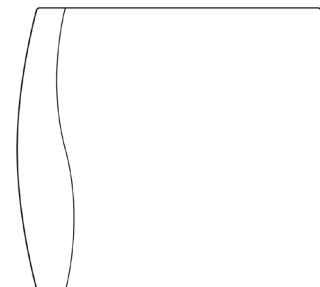

Ambient conditions	
Storage temperature	-25 °C to +50 °C
Operating temperature	-5 °C to +55 °C
Permissible air humidity	0 % RH to 95 % RH (without condensation)

Certifications / Standards	
Protection class	III (according to EN 60 730)
Protection type	IP 30 according to EN 60 529
Standards	CE conformity electromagnetic compatibility according to EN 61326 according to EMC Directive 2014/ 30/ EU

MW / KS / 05.09.2024

Testo Sensor GmbH

Housing		Drilling template
Material	not specified Material ABS	
Dimensions (L/W/H) (mm)	91 x 85 x 27	
Color	not specified	
Electrical connection	0.14 - 1.5 mm ² , via screw terminals on circuit board	

Your order code		M - Measured variable		Delivery and Packing	
Article number	Measured variable	code	Measured variable		
801110 6023	—	M1	% RH (Relative humidity)	Packing	individually packed in cardboard box
		M2	°C + % RH (Temperature and relative humidity)	Delivery	Transmitter, Operating instructions

Technical drawing	
Configurable options M - Measured variable	All dimensions in mm

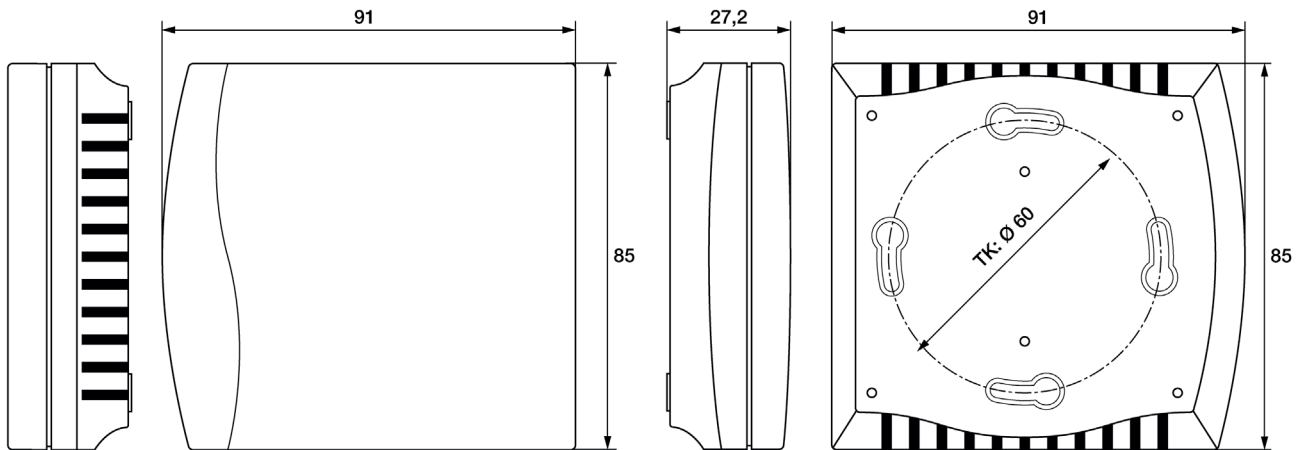

MW / KS / 05.09.2024

Testo Sensor GmbH

+49 7653 96597-71

Testo-Straße 1
D-79853 Lenzkirch

✉ webshop@testo-sensor.de

🌐 Please find our whole temperature probe and transmitter portfolio in our webshop at: www.testo-sensor.shop

Managing Director: Prof. Burkart Knospe, Martin Arndt, Timo Löffler

Amtsgericht Freiburg HRB 706025 | Umsatzsteuer-ID.: DE274417683

Important assembly instructions

For precise measurement of room temperature and humidity, it is crucial to take into account both the temperature dynamics and the humidity dynamics in the room. Air circulation should only take place through the openings in the housing cover. Therefore, the transmitter should be installed away from objects or obstacles that could block air movement. Also avoid uncontrolled air currents (draughts) by installing the transmitter near doors or windows. The transmitter should also not be installed on the colder outside wall to prevent measurement inaccuracies.

The device should only be used in pollutant-free, non-condensing air (< 95 % RH).

When connecting several probes to a common 24 V AC power supply, pay attention to the polarity to avoid short circuits. Please note that the voltage outputs are short-circuit-proof, but an overvoltage or the application of the power supply to the voltage output can destroy the device.

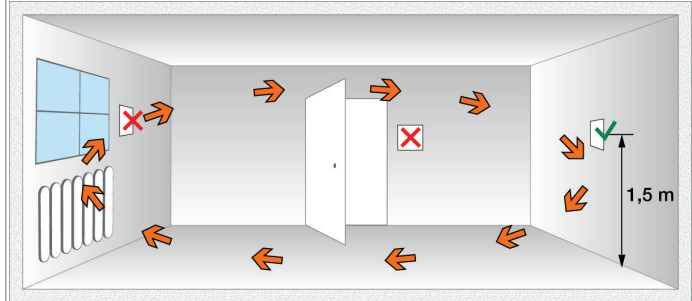

Circuit diagrams and assignment (Please also read the operating instructions before connecting the transmitter)

Wiring diagram

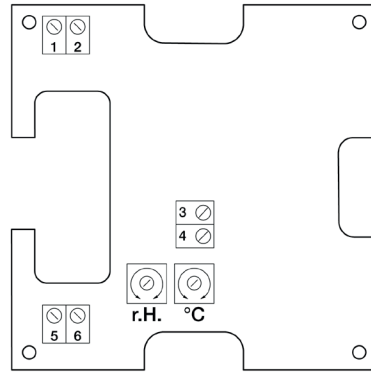

Assignment % RH	
1	+UB 24V DC
2	Output Humidity 0-10 V
3	free
4	UB GND
Assignment °C + % RH	
1	+UB 24V DC
2	Output Humidity 0-10 V
3	Output temperature 0-10 V
4	UB GND
5	free
6	free

Please observe the operating instructions for correct connection