

Screw-in probe with brass immersion sleeve

Article no.: 803015 1011

Our screw-in probe with brass immersion sleeve is mounted via the R1/2 " thread. With its polyamide housing, the screw-in probe is the perfect solution for measuring the temperature in pipes or containers. To configure your Screw-in probe for your measuring task, simply select the required configuration features and send us the order code.



General Information	
Measuring range	-30 °C to +150 °C depending on the sensor Type
Perm. range °C Housing	-30 °C to +90 °C
Accuracy	depending on sensor Type
Supply and output	
Max. meas. current	max. 1 mA
Supply voltage	approx. 5 V depending on measurement current
Measurement signal	passive (resistance value)
Ambient conditions	
Protection class	IP65 according DIN 60529
Humidity and moisture condensation resistance	according to application-specific qualification
Certificates and Standards	
Standards	DIN EN 61326-1:2013 DIN EN IEC 63000:2019-05
Directive	RoHS 2011/65/EU 2014/30/EU

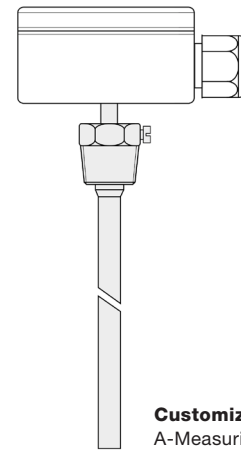

Customizable options

- A-Measuring element
- B-Connection Type
- C-Mounting length

A - Measuring element				
Code	Sensor	Accuracy / Tolerance resistance	From (°C) ¹⁾	To (°C) ¹⁾
A011	Pt100	Cl. A dT = ±(0,15 °C + 0,002 t) ¹⁾	-50 °C	+300 °C
A012	Pt100	Cl. B dT = ±(0,30 °C + 0,005 t) ¹⁾	-50 °C	+400 °C
A013	Pt100	1/3 Cl. B dT = ±(1/3 · (0,30 °C + 0,005 t)) ¹⁾	-50 °C	+200 °C
A014	Pt100	1/10 Cl. B dT = ±(1/10 · (0,30 °C + 0,005 t)) ¹⁾	±0 °C	+100 °C
A022	Pt500	Cl. B dT = ±(0,30 °C + 0,005 t) ¹⁾	-70 °C	+500 °C
A031	Pt1000	Cl. A dT = ±(0,15 °C + 0,002 t) ¹⁾	-50 °C	+300 °C
A032	Pt1000	Cl. B dT = ±(0,30 °C + 0,005 t) ¹⁾	-50 °C	+400 °C
A105	NTC 5 kOhm	R25 = 5 kOhm ±1 %	-40 °C	+125 °C
A110	NTC 10 kOhm	R25 = 10 kOhm ±1 %	-40 °C	+125 °C
A120	NTC 20 kOhm	R25 = 20 kOhm ±1 %	-40 °C	+125 °C
A210	Ni1000	-60 °C to 0 °C: dT = ±(0,4 °C + 0,028 · T) 0 °C to +150 °C: dT = ±(0,4 °C + 0,007 · T)	-60 °C	+150 °C
A323	LM235Z	typical ±1 °C	-40 °C	+125 °C
A421	KTY 81-210	R25 = 2 kOhm ±1 %	-50 °C	+150 °C
A411	KTY 81-110	R25 = 1 kOhm ±1 %	-50 °C	+150 °C
A520	DS18B20	-10 °C to +85 °C: ±0,5 °C -30 °C to +100 °C: ±1 °C -55 °C to +125 °C: ±2 °C	-55 °C	+125 °C
A334	LM34	typical ±0,5 °F at 77 °F ±1,5 °F at -50 °F to +300 °F	-50 °F	+300 °F

¹⁾according to IEC 751 / EN 60751 | ²⁾ Perm. range °C | A334 only on request | Detailed information and the characteristics can be found in our download area.

B - Connection Type	
Code	Conn. Type
B2	2-Wire (2W)
B3	3-Wire (3W)
B4	4-Wire (4W)

Possible connections			
Sensor	2W	3W	4W
Pt	✓	✓	✓
NTC	✓		
Ni	✓	✓	✓
LM235Z	✓		
KTY	✓		
DS18B20		✓	
LM34		✓	

Housing	
Material	Polyamide
Dimension (L/W/H) (mm)	64 x 58 x 35
Color	white similar RAL 9010
Cable entry	with strain relief
Clamping range (mm)	5 to 9
Electrical connection	Screw terminals max. 1,5 mm ²

Screw-in thread		C - Mounting length	
Material	Stainless steel 1.4571 316TI	Code	Length (mm)
Process connection	R1/2 "	C0050	50 ¹⁾
Protection sleeve		C0100	100 ¹⁾
Material	Stainless steel 1.4571 316TI	C0150	150 ¹⁾
Mounting length (mm)	please choose	C0200	200 ¹⁾
Ø (mm)	6 ¹⁾	C0250	250 ¹⁾
Immersion sleeve		C0300	300 ¹⁾
Ø immersion sleeve (mm)	8	C0400	400 ¹⁾
Material immersion sleeve	Brass nickel plated		
Pressure immersion sleeve	max. 16bar		

Other mounting lengths on request | ¹⁾Tolerance ± 1% | other protective sleeve lengths and Ø available on request | ¹⁾ Tolerance ± 0,1 mm

Your order code			
Article no.	Measuring element	Connection Type	Mounting length
803015 1011	A_____	B_____	C_____

Delivery and Assembly	
Assembly instructions	via immersion sleeve
Delivery and Packaging	Probe, separately packaged in PE bag

Important assembly advices

Measuring errors can occur due to heat dissipation to the environment. To keep these as small as possible, we recommend immersing the protection sleeve of your temperature probe as deep as possible into the medium to be measured during installation. The optimum installation depth should be 10-15 times the Ø of the protection sleeve or, if an immersion sleeve is used, the Ø of the immersion sleeve. When installing in pipes whose Ø does not have a sufficiently deep installation depth, you should either install the probe at an angle or in a pipe elbow. Make sure that you have enough space so that the probe can be removed again. 1) Installation with sufficient installation depth 2) Installation at an angle with small pipe Ø 3) Not like this: Minimum installation depth not reached

Installation by using an immersion sleeve (4): Please ensure that the Ø and length of the immersion sleeve are selected to suit the installation situation so that the minimum immersion depth can be achieved. Please also ensure that the process connection is correct. Because the probe is not inserted directly into the medium, but via the immersion sleeve, the response times are somewhat slower. The probe should be selected so that the protection sleeve touches the bottom of the immersion sleeve and the air cushion around the protection tube is as small as possible. The use of thermal conduction paste can improve the response times.

Please lay the cable so that no water can penetrate the probe and with a spare loop (4). This allows you to extend the probe without disconnecting the electrical connection.

KC / MWA / 21.06.2024

Testo Sensor GmbH

Technical drawing

Customizable options			
A - Measuring element	B - Connection Type	C - Mounting length	All dimensions in mm

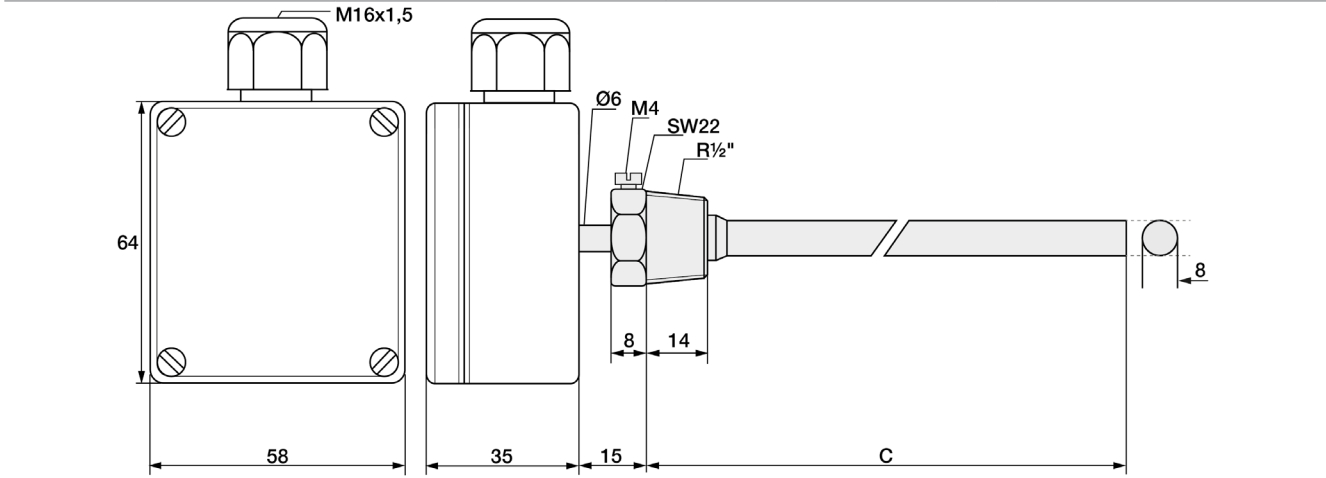

KC / MWA / 21.06.2024

Testo Sensor GmbH

Testo-Straße 1
D-79853 Lenzkirch

+49 7653 96597-71

webshop@testo-sensor.de

Please find our whole temperature probe and transmitter portfolio in our webshop at: www.testo-sensor.shop

Managing Director: Prof. Burkart Knospe, Martin Arndt, Timo Löffler

Amtsgericht Freiburg HRB 706025 | Umsatzsteuer-ID.: DE274417683

Matching accessories: Connection cable

Connection cable

Please select your desired cable first.

Picture	Code	Connection Type	Color	IP	From (°C) ¹⁾	To (°C) ¹⁾	Outside material	Material strand	Ø (mm) ²⁾	Q (mm ²) ³⁾	Color strand	Ω / m ⁴⁾
	809200 0	2-Wire	black	IP67	-30	+105	PVC	PVC	4,8	0,22	rd, wt	0,07
	809200 1	3-Wire	black	IP67	-30	+105	PVC	PVC	4,8	0,22	rd, wt, rd	0,07
	809200 2	4-Wire	black	IP67	-30	+105	PVC	PVC	4,8	0,22	rd, wt, rd, wt	0,07
	809210 0	2-Wire	red-brown	IP67	-50	+180	Silicone	Silicone	4,7	0,22	rd, wt	0,08
	809210 1	3-Wire	red-brown	IP67	-50	+180	Silicone	Silicone	4,9	0,22	rd, wt, rd	0,08
	809210 2	4-Wire	red-brown	IP67	-50	+180	Silicone	Silicone	4,9	0,22	0,08	0,08

Insulation resistance: ≥ 100 MOhm at min. 100 VDC | ¹⁾Perm. range °C | ²⁾Tolerance ± 0,2 mm | ³⁾Tolerance ± 0,03 mm² | ⁴⁾per single strand | ⁵⁾We use this cable only when using a DS18B20 or LM34 sensor. Litz color brown, green, white | Please also note the connection Type of your selected temperature sensor.

Now please select the length and add the code to the article no. of the cable.

Length (m)	1	2	5	10	20
Code	010	020	050	100	200

Please append these digits to the part number of your desired cable.

Matching accessories: Heat-conducting paste

Heat-conducting paste



Article no.	809540 1000
Content	10 ml
Thermal conductivity	>2.5 W/mK
Min / Max °C	-30 °C to +280 °C
Thermal resistance	< 0.126